

## Design and Development of IoT-Based Intelligent Patient Monitoring Systems for Continuous Health Assessment and Remote Care

Dr. Arjun Mehta<sup>1\*</sup>, Dr. Neha Sharma<sup>1</sup>

<sup>1</sup>All India Institute of Medical Sciences (AIIMS), Department of Biomedical Engineering and Medical Informatics, New Delhi, India

### ABSTRACT

The medical field is dealing with various problems such as regular monitoring of patients, the need for caretakers, emergency situations, keeping the patients' history or records safe for a long duration. This work demonstrates an intelligent way to supervise patients' vital signs. With the help of a sensor network, real-time physiological parameters of a patient's health are fetched and sent to the cloud using IOT. This data can be viewed by users and can verify these aspects from anywhere in the world. This will give huge relief for doctors since the doctors can detect changes in patient health parameters and monitor them only by visiting the Dashboard or URL. IOT has been really favourable whenever there is a need to monitor and manage history or records of changes in the health parameters of the patient over a period of time. Patients will now be serving the best quality benefits because the structure backs medical caretakers and staff by providing real-time data.

**KEYWORDS:** Arduino, Cloud, Dashboard, IOT, Wi-Fi Module.

---

### 1. INTRODUCTION

With an improvement in technology and miniaturization of sensors, there have been attempts to utilize the new technology in various areas to improve the quality of human life. The healthcare sector is the one main area of research that has seen the adoption of technology. In developing countries, it has been very difficult to avail of healthcare services since these services are very expensive. Thus this project attempts to solve the healthcare sector worries, which our society is facing today. It's comprised of three main sectors. The first sector being, data extraction of patient's vitals using sensors, the second sector is to analyze and send the collected data to the cloud and the last sector is to provide the analyzed data for remote viewing.

First of all Wireless Body Area Network is created. For this purpose, a range of sensors is used. Each sensor will be connected to the microcontroller. Medical and commercial sensors are used to calibrate wearable sensors data. A LabVIEW Graphical User interface (GUI) is constructed to display and assess the sensor signals locally. Sensor data will also be connected to the cloud either through GSM modem or Wi-Fi gateway [1]. Routing protocols are used to minimize the distance between source and sink. (to avoid a collision and improve energy efficiency). AODV is a routing protocol used for finding the shortest path and TDMA, CSMA, Zigbee protocols are used for performance analysis of the system[2].

To put detected information onto the server the Thingspeak named a new cloud is utilized. With the help of Thingspeak android app, the server information can be emphasized to the specialists and other medical staff [3]. A system called CogSense along with conventional sensors is used. This system captures human emotions and approximates physiological changes using a camera and voice recorder to identify human emotions and to predict physiological changes such as heartbeat and body temperature [4]. In a single user terminal containing GPRS module, to ensure reliability and integrity of data transmission, TCP/IP protocol is adapted [5]. The alerting system for the consumption of medicine and alarms for other abnormalities can be implemented. For this, Acquired values from the sensors are compared with the threshold values of each parameter [6]. Using multicamera and sensor network, Automatic Detection of Risk Situations and Alert (ADSA) can be done. For this, a hybrid architecture is introduced [7]. Nowadays, the data can be accessed by any permissible healthcare

facility in the form of compact and easy-to-wear m-Health devices like TICKR, Fitbit, etc. [8].

The proposed architecture aims at an efficient and effective remote health monitoring system to resolve healthcare issues. A doctor or health specialist can use the system to monitor all vital health parameters of the patient or person of interest remotely. Now Doctors do not have to visit the patient frequently. This project minimizes Hospital visits for normal routine checkups. This helps in time-saving.

### 2. PROPOSED DESIGN

In this section, we describe an improved patient monitoring system through the foundation of an automatic medical data gathering system in real-time and analysis in order to benefit clinicians in decision making. For this purpose, we have partitioned the design into several sectors these are:

### Data Extraction

Data Extraction is the heart of the entire system in which various sensors are deployed on the patients' bodies and also to the computing controller platform. Readings from the sensor will be collected here and processed according to the programming and then the physiological parameters of the patient will be displayed on the display unit. In case of abnormality in any parameter Alert along with stage of abnormality will be displayed.

### Communication Controller

The data extraction stage will pass on the readings to the controller platform. This sector has the provision to analyze all the parameters based on the programming and threshold values. Further, the analyzed report will be continuously transferred over the server via the Wi-Fi module.

### Decision Making

Decision making provides remote monitoring of the patients' physiological parameters at the healthcare care centres. Decisions regarding abnormalities will be taken according to the threshold values for each and every physiological parameter. This monitoring will be done by visiting the dashboard.

### Data Storage

Data Storage provides the facility to store the data regarding physiological parameters and previous records of the patient at the server. This data can be fetched back and can be utilized in the future.

### Feedback Action

In case of emergencies, a message or a panic will be sent using push notifications to the clinicians or doctors. On monitoring the data on the dashboard and considering the panic message, Doctors will reply a suitable action to be taken by health caretakers or nurse.

Here we have used Arduino UNO R3 as a controller platform of our monitoring system. IOT platform we used is Thingspeak. Arduino is interfaced with ESP8266 to connect with an internet router and access the cloud server. Arduino is also interfaced with a temperature sensor (LM35) and Heart rate sensor (Ky-039) to collect the physiological data of the patient. Then the measure data will be displayed on LCD and passed on to cloud platform by transmitting data to the Wi-fi access point. Freeboard.io is used as a dashboard to graphically represent the data. We have also used IFTTT platform to connect ThingSpeak to email/message service so that an alert message can be sent whenever the patient is in a critical state.

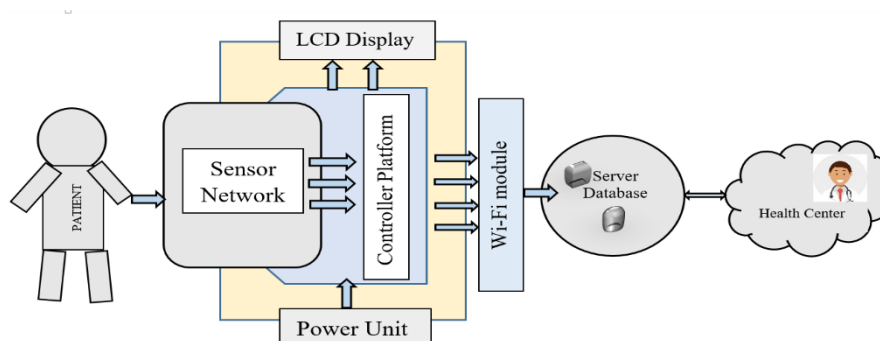

*Fig. 1. Proposed Design*

For sending messages in case of critical conditions push notifications are used. To send push notifications from ESP8266 Arduino compatible Wi-Fi module to Android / IOS mobile devices we have used Pushbullet. Pushbullet is an internet service which is used for SMS sending, notification management and file sending between mobile devices and pc.

## 3. EQUIPMENT

### Blood Pressure Sensor

The Blood Pressure sensor is used to measure the systolic and the diastolic pressure level using the device. Systolic and Diastolic blood pressure is determined by a measure of the pressure exerted by the blood in arteries

between heartbeats. It is measured in millimetre mercury (mmHg). It is necessary to continuously monitor the blood pressure of the patient.

**Table 1. Blood Pressure Stages**

Blood Pressure Stage	Systolic/diastolic pressure (mmHg)
Hypotension	< 90/60
Normal	90-119 / 60-79
Prehypertension	120.1-138.9/80.1-89.9
Hypertension stage 1	139-160/91-100
Hypertension stage 2	161-180/101-110
Hypertensive	>180/110

When the pressure falls below 90/60 mmHg or if it is increased above 180/110mmHg then it leads to death. So it is necessary to monitor blood pressure at a regular interval of time.

**Temperature Sensor (LM35)**

Temperature Sensor (LM35) is used to measure the temperature of the patients. It is necessary to monitor the temperature of the patients continuously. If the temperature falls to the lower level or even if it increased to a higher level then it leads to death.

**Table 2. Temperature Range**

Temperature Stage	Temperature Range (°C)
Normal	36 – 38
Hyperthermia	Between 38 to 39.9
1 <sup>st</sup> Stage of Hypothermia	Between 34.1 to 35.9
2 <sup>nd</sup> Stage of Hypothermia	Between 32.1 to 33.9
3 <sup>rd</sup> Stage of Hypothermia	Less than 31.9
Hyperpyrexia	Greater than 39.9

The table illustrates the temperature ranges for particular temperature stages or conditions of the patient's body. The perfect temperature will be read by the sensor and based on the programming the data will be analyzed and accordingly, the stage of temperature will be displayed.

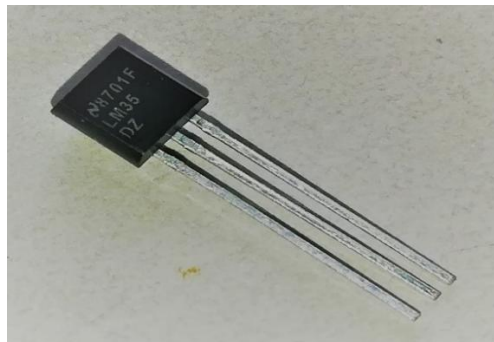

**Fig. 2. Temperature Sensor (LM35)**

**Wi-Fi Module (ESP8266)**

WI-FI or wireless fidelity module is used to connect the computer to the internet. It has the advantage that it can communicate over a larger distance. It is used to transfer the analyzed data from Arduino to the cloud. The Arduino Uno Wi-Fi module can be used as a Wi-Fi modem.

**Microcontroller**

The microcontroller used here is Arduino UNO which is based on the ATmega328P. ARDUINO UNO is used to analyze the information or data based on programming. It consists of 14 digital input/output pins out of which 6 can be used as PWM outputs, 6 analog inputs, 16 MHz quartz crystal, a USB connection, a reset button, an ICSP header, and a power jack.

**Heart Rate Sensor (Ky-039)**

To determine the pulse rate of the heart this sensor is used. The normal heartbeat of the person is 78 bpm. It is measured based in beats per minute. If the heartbeat per minute increases to 100 or becomes greater than 100 BPM then it leads to Tachycardia. If the heartbeat falls below than 60 BPM then it leads to Bradycardia.





location of the patient can be determined using the longitude and latitude received. This location is sent to the cloud via internet connectivity. This location or position will be key for doctors to attend the patients or to direct caretakers to take preventive cautions.

## REFERENCES

- [1] Mahmood, A. S., Sattar, E. J., Fernando, X. (2017)," Wireless Body Area Network Development for Remote Patient Health Observing", IEEE Canada International Humanitarian Technology Conference(IHTC), (pp. 26-31). Toronto, Canada.
- [2] Shaikh, S., Waghole, D., Kumbhar, P., Kotkar, V., Awaghade, P. (2017), "Patient Monitoring System using IOT", International Conference on Big Data, IOT and Data Science(BID), (pp. 177181). Pune, India.
- [3] Kumar, S. P. (2017), "Smart Health Monitoring System of Patient Through IOT", International Conference on I.SMAC, (pp. 551-556). Palladam, India.
- [4] Diwakaran, S., Mankonda, L., Morais, M., P., J. (2017), "IOT Clinic-Based Patient monitoring and Diagnosis System", IEEE International Conference on Power controls, Signal, and Instrumentation Engineering (ICPCSI), (pp. 2858-2862).
- [5] Liu, H. (2016), "Remote Intelligent Monitoring System Based on Internet of Things", International Conference on Smart Grid and electrical Automation (ICSGEA), (pp. 42-45). Zhangjiajie, China.
- [6] Premalatha, G., Thulasibai, V. (2018), "An Effective Patient Monitoring System Using IOT", Fourth International Conference on Electrical, Electronics, Information, Communication, and Bioinformatics (AEEICB), Chennai, India.
- [7] Ahoundjnou, A. S., Assogba, K., Matamed, C. (2016), "Smart pervasive ICU based IOT for improving Intensive Healthcare", International Conference on Bio-engineering for smart technologies (Bio-Smart), Dubai, United Arab Emirates.
- [8] Almotiri, S. H., Khan, M. A., Al-Ghamdi, M. A. (2016), "Mobile Health (m-health) System in the Context of IOT," 4th International Conference on Future Internet of Things and cloud Workshops, (pp. 39-42). Vienna,Austria